

TECHNICAL NOTE

Filing Code 1525 (P-713e)

Date Issued

Bureau of Land Management U.S. DEPARTMENT OF THE INTERIOR

HOW TO INSPECT BALL JOINT SUSPENSIONS

Many good ball joints are being condemned to the junk heap because of improper inspection. Studies show that an alarmingly high percentage of replaced ball joints should not have been replaced because they actually were not worn. In most instances, the car was not properly jacked before the inspection was made.

Ball joint suspension systems require two specific inspections:

1. Inspection of a steering and suspension.
2. Inspection of the ball joint.

Steering and suspension inspection:

1. Jack the car according to the position of the front coil spring.
2. Jack at the frame or cross member if the spring is supported on the lower control arm (Figure 1).
3. Jack at the lower control arm if the spring is supported by the upper control arm (Figure 2).
4. Check the steering wheel lash, condition of springs, shock absorbers, stabilizer links, and steering linkage.
5. Check proper adjustment of wheel bearings before making the ball joint wear inspection.

Ball joint wear inspection: The car must be jacked to unload ball joints before the inspection is attempted. A certain amount of looseness is designed into ball joints when they are unloaded. As a result, looseness alone is not the cause of replacement. Replace only when ball joint wear is excessive.

1. Car with the spring on the lower control arm:
 - a. Jack at the lower control arm.
 - b. Check for ball joint wear by moving the tire in and out (Figure 3), and up and down (Figure 4).



- c. Replace the lower ball joint if wear exceeds the manufacturer's tolerances.
2. Car with the spring on the upper control arm:
 - a. Jack up the frame or cross member.
 - b. Check for ball joint wear by moving the tire in and out (Figure 5), and up and down (Figure 6).
 - c. Replace the upper ball joint if wear exceeds the manufacturer's tolerances.

In making the ball joint tests, do not confuse wheel bearing looseness with ball joint wear.

Allowable wear tolerances for all vehicles are given in the Inspection Handbook prepared by the Automobile Manufacturer's Association in cooperation with the American Association of Motor Vehicles Administrators.

Enclosures: (1)
As noted above

1. The first part of the document is a list of names and addresses of the members of the committee.

2. The second part of the document is a list of names and addresses of the members of the committee.

3. The third part of the document is a list of names and addresses of the members of the committee.

4. The fourth part of the document is a list of names and addresses of the members of the committee.

5. The fifth part of the document is a list of names and addresses of the members of the committee.

6. The sixth part of the document is a list of names and addresses of the members of the committee.

7. The seventh part of the document is a list of names and addresses of the members of the committee.

8. The eighth part of the document is a list of names and addresses of the members of the committee.

9. The ninth part of the document is a list of names and addresses of the members of the committee.

10. The tenth part of the document is a list of names and addresses of the members of the committee.

11. The eleventh part of the document is a list of names and addresses of the members of the committee.

12. The twelfth part of the document is a list of names and addresses of the members of the committee.

13. The thirteenth part of the document is a list of names and addresses of the members of the committee.

14. The fourteenth part of the document is a list of names and addresses of the members of the committee.

15. The fifteenth part of the document is a list of names and addresses of the members of the committee.

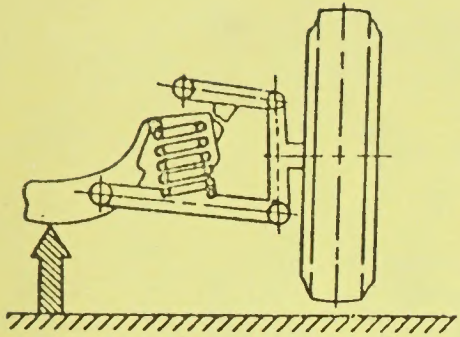

1. Spring supported on lower control arm.

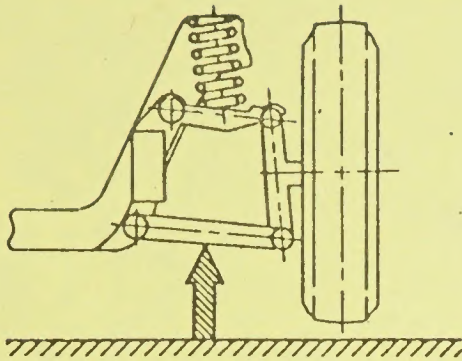

2. Spring supported by upper control arm.

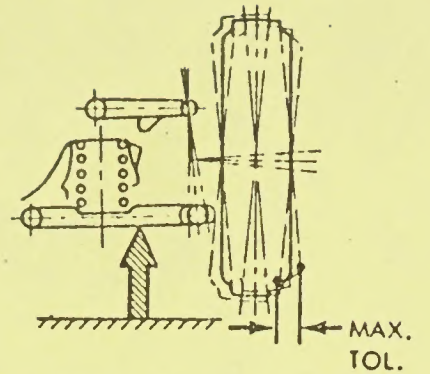

3. Rock tire top and bottom.

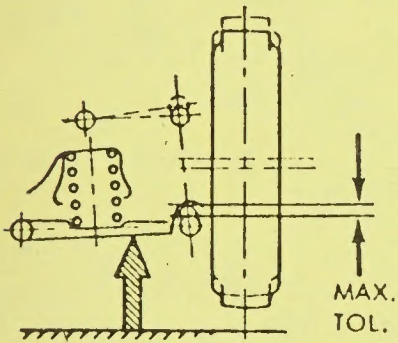

4. Move tire up and down.

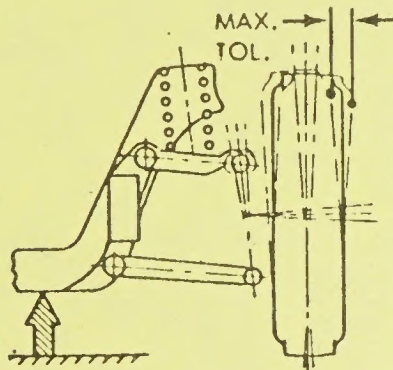

5. Rock tire top and bottom.

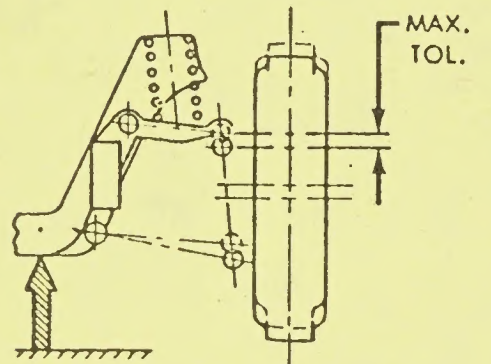

6. Move tire up and down.

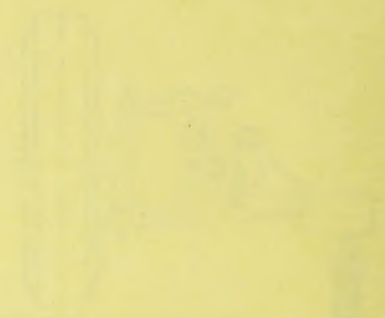
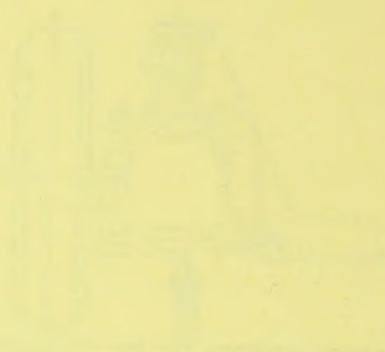
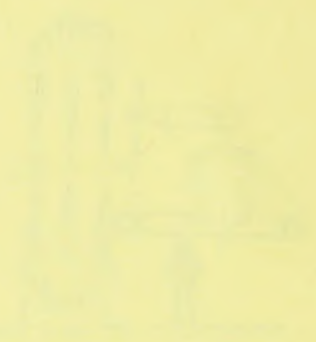

Faint text caption below the first sketch.

Faint text caption below the second sketch.

Faint text caption below the third sketch.

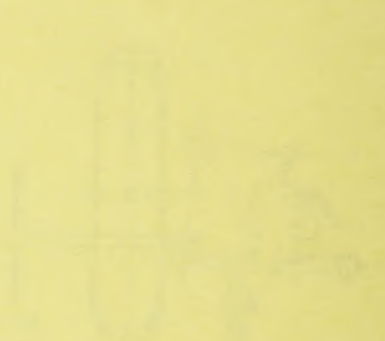
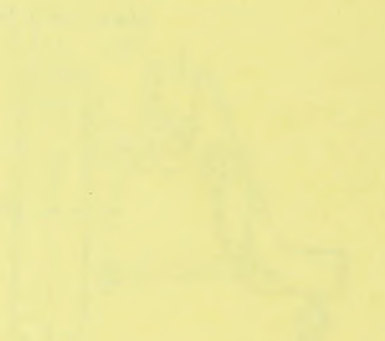
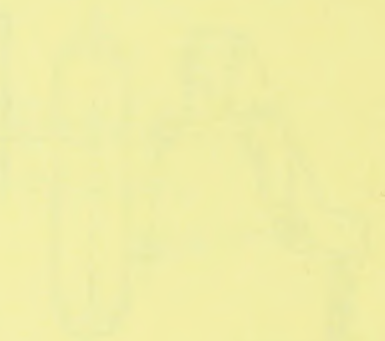

Faint text caption below the fourth sketch.

Faint text caption below the fifth sketch.

Faint text caption below the sixth sketch.